



# Terminal Emulator II

SOLID STATE  
SOFTWARE™

## COMMAND MODULE

*Enables your Home Computer to telecommunicate with other computer systems. Features include color graphics, speech, sound, and file transfer capabilities, if the subscription data-base service uses the Terminal Emulator II protocols. Check with your data-base service to find out if it supports these features.*

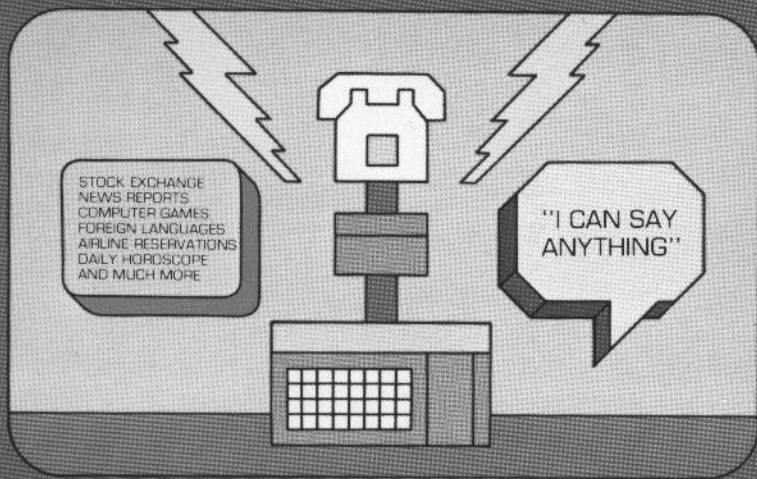

*This module requires use of a Texas Instruments RS232 Interface (Model PHP1700) — not included (details inside). If you are contacting a remote computer via telephone, a TI Telephone Coupler (Modem) or other RS232C-compatible modem is also required.*

## Quick Reference Guide

### Communication Characteristics:

<u>Parameter</u>	<u>Acceptable Values</u>	<u>Default</u>
BAUD RATE	110, 300	300
PARITY	EVEN, ODD, NONE	EVEN
DUPLEX	FULL, HALF	FULL
RS-232 PORT	#1, #2	#1
COLUMN WIDTH	40, 38, 36, 34	40
AUTO LOG-ON	(any appropriate file name)	LOGON

The following are some important keystroke sequences.

<u>Press</u>	<u>Action</u>
CTRL 1 (SPEAK)	Instructs the computer to speak displayed data aloud. (Note: The Solid State Speech™ Synthesizer must be connected to the computer to utilize the speech capability.)
CTRL 2 (OUTPUT)	Outputs data to a printer or mass storage device attached to the computer.
CTRL 3 (CANCEL)	Cancels an automatic log-on sequence, file transfer, or output to a mass storage device.
CTRL 4 (TRANSFER)	Transfers a file of information to the other system. (Note: File transfers made from diskette can only be performed with the TI. Disk Memory System.)
CTRL 5 (WRAP)	Turns the WRAP feature off or back on. (Note: Changing the WRAP setting causes all data stored in memory to be erased.)
CTRL 6 (CASE)	Changes the case of the letters being sent to the other system.
CTRL 7	Allows text to be scrolled a page at a time.
CTRL 0 (EXIT)	Closes all open files and properly exits the program. Note: All data not saved on a mass storage device will be lost. Also note that pressing <b>QUIT</b> will not properly close open files and may result in the loss of saved data.
FCN V (DELETE)	Transmits a DELETE control character (ASCII 127) to the other system.



TEXAS INSTRUMENTS  
HOME COMPUTER

## Terminal Emulator II

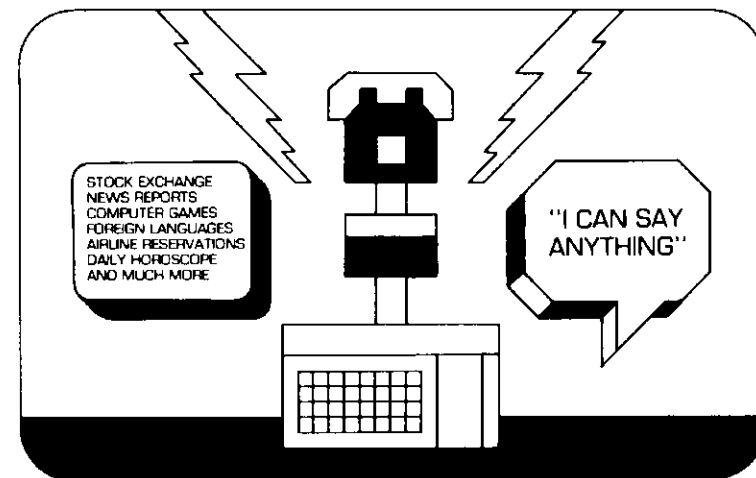

This Solid State Software™ Command Module is designed to be used with the Texas Instruments Home Computer. Its preprogrammed solid-state memory expands the power, versatility, and capability of your Home Computer.

**TABLE OF CONTENTS**

Introduction .....	3
Suggested Methods of Access .....	5
Using the <i>Solid State Software</i> ™ Command Module .....	7
A Sample Application .....	8
Preparing to Send/Receive Data .....	11
Baud Rate .....	11
Parity .....	11
Duplex .....	11
RS-232 Port .....	12
Column Width .....	12
Auto Log-on .....	12
Sending/Receiving Data .....	13
Data Reception Features .....	13
Ending Data Exchange .....	14
Special Function Keys .....	14
Types of Functions .....	15
Using the Function Keys .....	16
File Transfer .....	21
File Transfer to Another System .....	22
File Transfer from Diskette .....	22
File Transfer from Cassette .....	23
File Transfer in Progress .....	23
Transmission of Graphics and Sound .....	24
Reviewing Data with the Arrow Keys .....	25
<i>Appendix A</i> (Standard ASCII Control Characters) .....	26
<i>Appendix B</i> (Setting Up a Log-on File) .....	28
<i>Appendix C</i> (Accessing Text-to-Speech in TI BASIC) .....	33
Caring for the Module .....	42
In Case of Difficulty .....	43
Warranty .....	44



**INTRODUCTION**

Few developments are changing the world today as rapidly as the "information explosion." As a part of this explosion, data-base services are giving people quick access to information ranging from French lessons to the latest price of gold. For the first time, electronic mail, airline scheduling, and other valuable services are available at low cost to home computer users.

The Terminal Emulator II *Solid State Software*™ Command Module enables you to explore these and many other benefits of telecommunications. In addition, if the *Solid State Speech*™ Synthesizer is connected to your computer, *any* data that you receive can be spoken. The module also allows you to access the text-to-speech capabilities with a TI BASIC program. With this text-to-speech feature, you can add speech to games, educational programs, and many other applications. However, the Terminal Emulator II module's text-to-speech cannot be used with the TI Extended BASIC module.

*Note:* To activate the telecommunications capabilities of the Terminal Emulator II module, a TI RS232 Interface (Model PHP1700)\* must be attached to your computer. If you are contacting a remote computer via telephone, a TI Telephone Coupler (Modem)\* is required in addition to the TI RS232 Interface.

The Terminal Emulator II module brings new dimensions to telecommunications. The module allows you to send and receive color graphics and music, as well as text. It also includes a wide variety of special functions that help you access and work with your data.

With the Terminal Emulator II module, your Home Computer functions like a standard RS232 terminal, enabling you to communicate with any data base or large remote system operating under the standard RS232 protocols. However, since the data base you are communicating with must be equipped to take advantage of the module's special features, such as color graphics, sound, speech, and file transfer, we recommend that you check with the subscription service before attempting to access these features.

With the Terminal Emulator II module, you can:

- Select the parameters that enable your Home Computer to communicate with other systems.
- Transmit control characters that signal the remote computer to perform predefined functions.
- Receive data in the most appropriate display mode — *text mode* for alphanumeric data, or *graphics mode* for games, simulations, and other transmissions that involve color graphics.
- Send and receive upper- and lower-case characters.
- Vary the column width of your display to prevent the loss of characters off either end of the display.
- Scroll displayed information by line or by page, vertically or horizontally.

In addition, if the TI Disk Memory System (Disk Drive Controller and Disk Memory Drive)\* is connected to your Home Computer, you may set up a file on diskette so that you can automatically log on to the remote system. You can also transfer files to and from a disk system or cassette recorder. During file transfer, the module even checks for data that may have been dropped or garbled during transmission and asks for a retransmission, if necessary.

If two Home Computer systems have a Terminal Emulator II module, files can be transferred easily. However, sending graphics, sound, and speech requires a complex and time-consuming procedure, including special coding before entering the data one character at a time. In addition, special handling is required to make selective use of speech, not to speak all of the text on a display. For more information, see "Transmission of Graphics and Sound."

**Note:** The Terminal Emulator II module cannot access the Memory Expansion Unit.

\*sold separately



### SUGGESTED METHODS OF ACCESS

You have access to a variety of computer systems depending on the accessories used with the Home Computer and Terminal Emulator II Command Module. The following diagrams illustrate two typical arrangements.

#### Accessing Subscription Data Services or a Remote Computer System

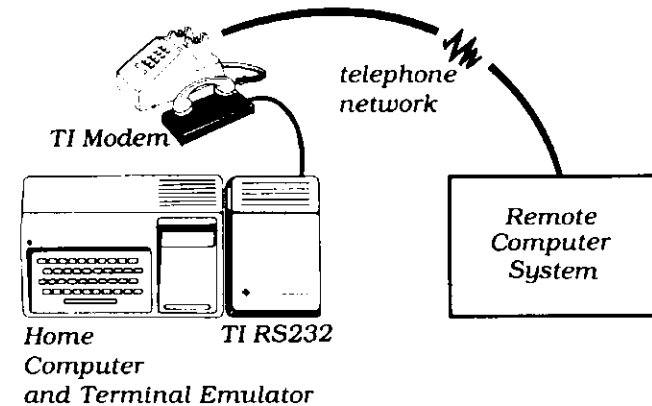

Generally, your Home Computer will communicate with a subscription data-base service or other remote system over the telephone lines, as shown here. In this situation, your Home Computer system needs the TI RS232 Interface and the TI Telephone Coupler (Modem) — or other RS232C-compatible modem — to communicate with the other system. If your computer is located near the other system, you may be able to communicate with the other system by direct cable. The direct cable eliminates the need for modems and telephone calls, but the RS232 Interface is still required. (See the TI RS232 Interface owner's manual for information on linking your computer to the other system by direct cable.)

**Note:** To access a data-base service, you must subscribe to the appropriate service and pay any required fees. Most computer-related magazines include information on available data-base services.

**Communicating with a Remote Home Computer**

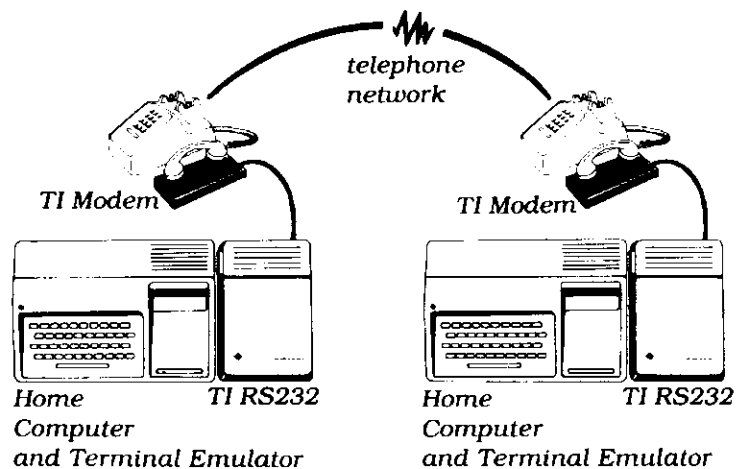

Communication between two Home Computers usually takes place over telephone lines, as shown here. In order to communicate by telephone, both computers need an RS232 Interface and a TI Telephone Coupler (Modem). With two modems in use, one must be set to Originate and the other one to Answer. If the two Home Computers are in the same location, however, they can be connected by direct cable, without modems. In either case, each Home Computer needs a TI RS232 Interface and Terminal Emulator II (or Terminal Emulator I) module.

*Note:* To transmit features, such as sound, color, and graphics, which are unique to Terminal Emulator II, both systems must have a Terminal Emulator II module.

**IMPORTANT:** To utilize the module's speech capabilities, the TI Speech Synthesizer must be connected to the console first, with other accessories connected to the right of the speech unit. See the Speech Synthesizer owner's manual for full set-up instructions.



**USING THE SOLID STATE SOFTWARE™ COMMAND MODULE**

An automatic reset feature is built into the computer. When a module is plugged into the console, the computer returns to the master title screen. All data and program material you have entered will be erased, unless it has previously been stored on a cassette tape or diskette.

*Note:* Be sure the module is free of static electricity before inserting it into the computer (see page 42).

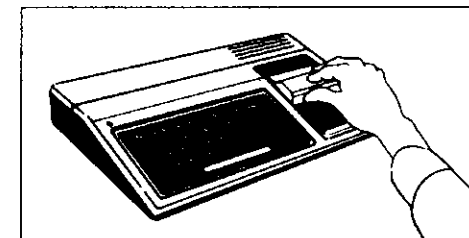
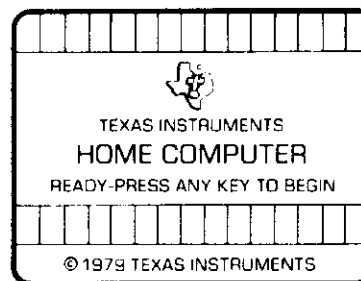

1. Turn the computer ON and wait for the master title screen to appear. Then slide the module into the slot on the console.
2. Press any key to make the master selection list appear. Two options for TERMINAL EMULATOR II appear on this list. The difference between these two options concerns the instructions (*parameters*) that you set to enable your computer to communicate with another system. If you select *Terminal Emulator II*, the module allows you to set the parameters yourself. If you select *Default Option TE II*, the module automatically assumes a set of "default" parameters, as listed in the "Quick Reference Guide," and the display clears for data exchange (see "Sending/Receiving Data"). Press the key corresponding to the number beside the desired option.

*Note:* To remove the module, *first* return the computer to the master title screen by holding down the **CTRL** key and pressing **0** (EXIT). Then remove the module from the slot. If you have any problem inserting the module, or if it is accidentally removed from the slot while in use, please see "In Case of Difficulty" on page 43.

### A SAMPLE APPLICATION

When you select *Terminal Emulator II* from the master selection list, the module's title screen appears. Press any key at this time to go to the COMMUNICATION SETUP display. (If you wait a few moments, this display automatically appears.)

COMMUNICATION SETUP		
PARAMETER	OPTIONS	CHOICE
BAUD RATE	1 - 300	1
	2 - 110	
PARITY	1 - EVEN	1
	2 - ODD	
	3 - NONE	
DUPLEX	1 - FULL	1
	2 - HALF	
RS-232 PORT	1 - #1	1
	2 - #2	
COLUMN WIDTH	1 - 40	1
	2 - 38	
	3 - 36	
	4 - 34	
AUTO LOG-ON	FILE = LOGON	

For demonstration purposes, suppose that you have subscribed to the XYZ Data Service. Since you are communicating with the service by phone, your Home Computer system includes a TI RS232 Interface and a TI Telephone Coupler (Modem), properly connected to the computer and turned ON. (Refer to the RS232 Interface and modem owner's manuals for set-up instructions.)

Before you can establish communication with XYZ, you must select the parameters necessary for proper data exchange with the XYZ computer. To determine these parameters, refer to the section "Preparing to Send/Receive Data" in this manual and to the user's manual(s) supplied by XYZ. Assume that you determine that your Home Computer is to be set at these values:

BAUD RATE = 300  
PARITY = EVEN  
DUPLEX = FULL  
RS-232 PORT = #2  
COLUMN WIDTH = 40  
AUTO LOG-ON = (no auto log-on)



The parameters are shown on the left side of the COMMUNICATION SETUP display, and the available options for each parameter are listed in the center. The default parameters appear on the right-hand side of the display, with the cursor (a flashing square) on the first entry.

Notice that all the default values except RS-232 PORT and AUTO LOG-ON agree with the values required to communicate with XYZ. Press **ENTER** three times to accept the first three values. The cursor now appears to the right of RS-232 PORT. Press **2** to select port #2, and then press **ENTER** twice to move the cursor to LOGON.

If you make a mistake, move the cursor back up to the entry by pressing **FCTN** ↑ (UP). Retype the desired selection, and then press **ENTER** repeatedly to move the cursor down to LOGON.

At this point, if you were using the module's automatic log-on feature, you would insert the appropriate diskette into Disk Drive One and enter the file name of your log-on program. For this demonstration, however, we are not using the auto-log-on feature. Therefore, simply press **ENTER** to accept the default value LOGON.

Once you press **ENTER**, the module conducts a search for the log-on file. (If you replace the "L" in "LOGON" with a space, the module does not search for the file and beeps immediately to indicate that you have control.) For several seconds, the screen is blank and the keyboard does not respond to any key presses. Once the search is ended, the module "beeps" to indicate that control has been restored to you. You may then continue with the program.

At this point, the computer shows only the cursor in the upper left-hand corner of the display. To begin actual communication with XYZ, dial the telephone number supplied by the data base. When you finish dialing the number, listen for a high-pitched tone, and then correctly place the telephone receiver in the modem cradle. *Note:* If you are using the auto-log-on feature, be sure to dial the data base's telephone number when the cursor is on the log-on file name and before you press **ENTER**.

Next, a series of messages appear, asking you to enter one or more codes. Refer to the manual supplied by XYZ, and enter the codes as they are requested.

Some of the codes may need to be sent as *control characters*, which are special characters that signal the other system to perform a predefined function.

To send the control characters, hold down the **CTRL** key as you press each letter and number in your code. Since each character is sent as soon as you type it, you do not need to press **ENTER** after you type the code.

After you have correctly "signed on," XYZ sends a message to let you know that you have done so. Then refer to the XYZ instruction manual to select the data you'd like to access.

When you have received the information you want, you can stop the transmission by using the proper code (again provided by XYZ). For this example, the XYZ instruction manual says to send a **BREAK** signal and then enter "BYE." To send the **BREAK** signal, hold down the **CTRL** key and press **ENTER**. Then type **BYE** and press **ENTER**, if necessary, to end the transmission. To exit the module and close all open files properly, press **CTRL O (EXIT)**.

The remainder of this manual explains the various options included in the Terminal Emulator II module. The section "Preparing to Send/Receive Data" explains each parameter and tells you how to set up the Home Computer for proper data exchange. The section on "Sending/Receiving Data" provides instructions for beginning data exchange, a description of what is displayed on the screen, and information on terminating data exchange. The "Special Function Keys" section discusses the keyboard overlay and explains how to use the module's many available functions. The "File Transfer" section explains how to transfer files of information between two systems. The last section, "Reviewing Data with the Arrow Keys," explains how to review data stored in your computer's memory.



### PREPARING TO SEND/RECEIVE DATA

To prepare the Home Computer for data exchange, begin by describing the parameters required by the computer system with which you're communicating. The module's default values are shown to the right of each parameter on the COMMUNICATION SETUP display. Check these values against the specifications of your system and the other system. The specifications of your system are provided in the TI RS232 Interface and modem owner's manuals. The other system must provide you with its specifications.

The parameters are as follows:

#### **Baud Rate**

Baud Rate is the data transmission speed in bits per second. The higher the Baud Rate, the faster the transmission. The speeds you can specify are 110 or 300, as determined by the other computer system.

#### **Parity**

Parity (ODD, EVEN, or NONE) is the means for detecting any errors which might occur during data transmission from the Home Computer. To ensure proper reception of data, the computer adds the value of the bits transmitted for each character. This sum should be odd for ODD parity and even for EVEN parity.

The type of parity you choose usually depends on the other system. Check the other system's instruction manual for proper selection. If the remote computer does not require a parity bit, select NONE. *Note:* The module does not check parity for errors in transmission to your Home Computer.

#### **Duplex**

The duplex setting is a means of transmission between systems which echoes characters back to the Home Computer display. Since the requirements of the other computer system control the duplex setting, check the other system's instruction manual for the proper selection.

FULL duplex means the other system echoes all characters you type back to your display. The HALF duplex setting instructs the Terminal Emulator II module to echo the characters you type back to your display as they are transmitted to the other system. For proper communication between two Home Computers, both should specify HALF duplex. *Note:* The TI Telephone Coupler (Modem) should always be set on FULL (switch set to F on the modem).

### RS-232 Port

This parameter lets you indicate which RS232 Interface port you are using to communicate with the other system. For instance, if your modem cable is connected to port #2 of your RS232 Interface (the port to the right as you face the front of the unit), select option 2 for this parameter on the COMMUNICATION SETUP display.

### Column Width

The column-width parameter allows you to set the optimum number of characters per line for your monitor or television screen. A common problem with using a television set instead of a monitor as your video display is *overscan* (the loss of characters off either side of the screen). You can avoid overscan by adjusting the column width to suit your television set. As a rule of thumb, the older the television set is, the narrower the column width probably is. If you are using a monitor, the default setting of 40 columns is usually appropriate.

### Auto Log-on

This feature instructs the Home Computer to send out automatically the control characters that enable your Home Computer to begin data exchange with the other system. The use of this feature requires that: (1) the TI Disk Memory System be attached to your computer and properly turned on, (2) an appropriate log-on data file be stored on diskette (see Appendix C), and (3) the diskette with the log-on data file be inserted in Disk Drive One (the disk drive that is connected directly to your Disk Drive Controller).

Simply type in the name you have assigned the file (the default file name is LOGON). Next, if you are communicating via telephone, call the other system, correctly place the telephone receiver in the modem cradle, and press **ENTER**. If you are not communicating with the other system by telephone, just press **ENTER**. After you press **ENTER**, the log-on file is sent out to the RS232 Interface for transmission to the other system. While the transmission is in progress, you may cancel the log-on procedure by pressing **CTRL 3** (CANCEL).

*Note:* If the first entry in the input field (the "L" in "LOGON") is a blank space, the module will not search for a log-on file.

If you are *not* using the automatic log-on feature, press **ENTER** to accept the default value LOGON. After a few seconds, the computer beeps, and you may then send the necessary control characters manually.



### SENDING/RECEIVING DATA

After you select the parameters necessary to communicate with the other computer system, you are ready to begin data exchange. As discussed in "A Sample Application," this procedure varies, depending on the system with which you wish to communicate. Check the other system's instruction manual to determine the proper procedure for starting the exchange. If you are using a modem and the telephone network to communicate over a longer distance, include the following steps to begin communication.

1. Dial the telephone number of the remote computer system.
2. Verify that the remote computer is ready to communicate (usually signalled by a high-pitched tone).
3. Place the telephone receiver in the modem cradle. Be sure to align the telephone receiver and its cord as specified in the modem owner's manual. (*Note:* If you are using the automatic log-on feature, press **ENTER** while the cursor is positioned on your log-on file name on the COMMUNICATION SETUP display.)
4. Begin communication with the remote computer by typing in the codes or other information it requires. These inputs are included with the remote system's instructions. *Note:* If you are using the automatic log-on feature and the other system echoes the codes that you have included in your log-on file, the codes are displayed automatically as your computer sends them to the other system.

### Data Reception Features

After you have properly accessed the other system, the display shows the data your computer is receiving. The lines of information appear on the screen one at a time from top to bottom. When the cursor reaches the end of the bottom line, the text scrolls up, one line at a time, and new data is displayed on the last line.

At times, the computer system transmitting data to the Home Computer display may want to clear the display. If the other system sends a control L, the Home Computer recognizes the signal and clears the screen. The cursor automatically moves to the upper left-hand corner of the display.

If the other system wants to move the cursor to the upper left-hand corner of the display ("home" position) and sends a control A or escape H, the Home Computer repositions the cursor. The next data received begins at this position.



**IMPORTANT:** The Terminal Emulator II Command Module sequentially stores incoming data in the Home Computer's available Random Access Memory (RAM). As the data is received, it is added to the end of the most recently received information. When the available RAM is filled, the computer sounds a loud beep, and any data received from then on replaces the oldest data stored in memory. With 40-character line lengths, about six pages can be stored before the first page is replaced by new data. With 80-character line lengths (WRAP OFF), about three pages can be stored.

### Ending Data Exchange

After receiving your desired information, you usually have several methods available for ending the data exchange. For the most effective method of ending the exchange, refer to the other system's instruction manual. If you are using a modem, you can also end the exchange by removing the telephone from the modem cradle and hanging it up. In most cases, this will automatically log you off the other system. *In some cases, however, it may not.* Check with the instruction manual of the other system to be sure.

When you have completed the data exchange, the last information received is still displayed. At this point, you may want to review the information, or you may want to store the data on a mass-storage device. Both of these alternatives are explained in the following sections.

### SPECIAL FUNCTION KEYS

The Terminal Emulator II module features a wide variety of functions that help you communicate with the other system and work with your data. The functions fall into two basic categories: those that signal the other system to perform a predefined function and those that help you work with your data. Most of the functions in this second category are control characters in the ASCII Character Set. For a listing and explanation of the ASCII control characters available with the module, see *Appendix A*.

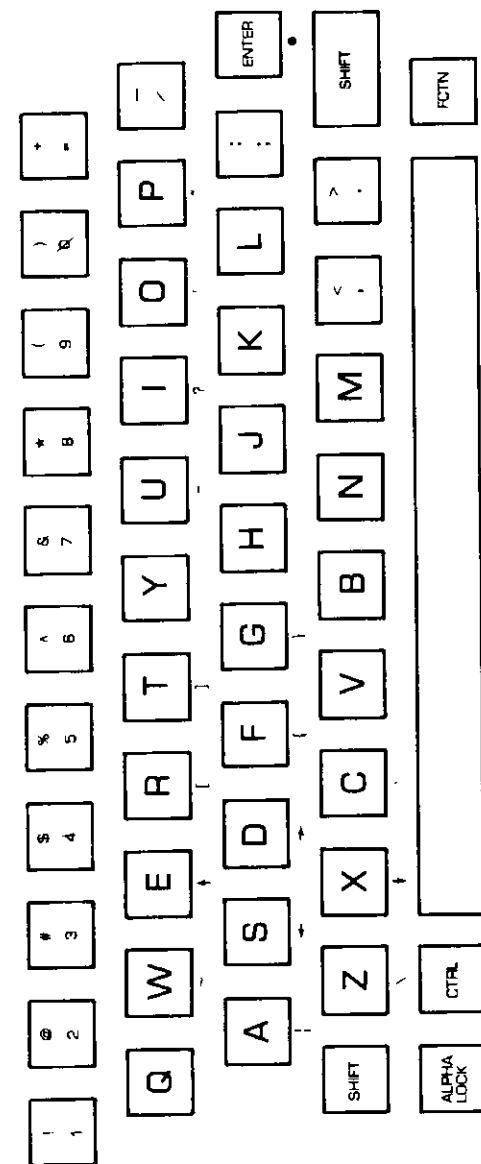



### Using the Function Keys

While exchanging information, you may find it necessary to perform various functions. For example, you may want to output to a mass storage device or change the case of the characters you are sending to the other system.

You can select a function after you finish selecting the parameters on the COMMUNICATION SETUP display. If you want to select a function while receiving data, it is best to do so when the other system pauses while sending data. In most cases, the Home Computer will store incoming data in a *temporary* 256-character buffer while you are using a function. This allows about eight seconds of transmission (at 300 Baud) before the buffer overflows and the first data received is lost.

**IMPORTANT:** Incoming data is *not* stored while your Home Computer is performing the **CTRL 1 (SPEAK)** or **CTRL 2 (OUTPUT)** function or if you are pressing the paper advance button on the TI Thermal Printer.

Once a function is performed, the information stored in the buffer is quickly displayed. When the displayed information catches up to the remote system's transmissions, the characters appear at normal speed. If some of the information seems to be missing, the data transmitted probably exceeded the buffer's limit.

The remainder of this section describes the various functions available with the Terminal Emulator II module, *except* the ASCII control characters 1 through 31. For a listing of these ASCII characters, see *Appendix A*.

### CONTROL 1 (SPEAK)

Holding down the **CTRL** key and pressing **1** instructs the Home Computer to speak all the text displayed on the screen. Pressing **CTRL 1 (SPEAK)** has no effect unless the TI *Solid State Speech*<sup>™</sup> Synthesizer is properly attached to your Home Computer. For information on accessing text-to-speech in a TI BASIC program, see *Appendix C*. *Note:* You cannot use **CTRL 1** when you are in the graphics mode.

### CONTROL 2 (OUTPUT)

Holding down the **CTRL** key and pressing **2 (OUTPUT)** allows you to transmit a page of *currently displayed data* to a printer or a mass storage medium, such as a cassette tape or diskette. Once you press **CTRL 2 (OUTPUT)**, the module asks you to enter the device name. The module accepts any of the following device names, provided the device is properly connected to the computer and turned ON.

Device Name	Refers to
DSK1.filename	Disk Drive 1, 2, or 3 of the TI Disk
DSK2.filename	Memory System
DSK3.filename	
CS1	cassette recorder 1 or 2
CS2	
TP	TI Solid State Thermal Printer
RS232/1	RS232C-compatible printer or disk
RS232/2	system connected to port 1 or 2 of the TI RS232 Interface

**IMPORTANT:** If your computer is outputting to a device attached to the RS232 Interface, be sure that you do not specify the same port that you are using to communicate with the other system. Otherwise, you will lose your connection.

The module also accepts the device name of any other TI-99/4 Home Computer output device (see the appropriate owner's manual for the proper device name format).

Type the appropriate device name and press **ENTER**. The display then shows the message PLEASE WAIT WHILE WRITING DATA. If the specified device is the TI Thermal Printer, the module automatically reformats the data in memory and prints 32 characters per line.

When the computer finishes writing a page, the previously displayed data reappears. To output additional data, press **CTRL 2 (OUTPUT)** again. The program then asks if you wish to OUTPUT TO PREVIOUS DEVICE and offers you the choice of pressing **1** for "yes" or **2** for "no." To save additional data, enter **1**. (*Note:* If you are saving data on a disk system, the file is closed when you press **2** for "no." Once the file is closed, you cannot add additional information to it.)



### **CONTROL 3 (CANCEL)**

Pressing **CTRL 3 (CANCEL)** cancels the following functions while they are in progress: the automatic log-on sequence, file transfer, and output to a mass storage device.

### **CONTROL 4 (TRANSFER)**

Holding down the **CTRL** key and pressing **4 (TRANSFER)** enables you to transfer a file of information from your cassette or diskette to the other system. See the "File Transfer" section for full information.

### **CONTROL 5 (WRAP)**

**CTRL 5 (WRAP)** controls the status of the wrap-around feature. The module begins with WRAP automatically ON. With the wrap-around feature on, the module breaks lines at blank spaces whenever possible and continues long lines of text on the next line instead of extending the text beyond the right screen boundary. When you press **CTRL 5 (WRAP)**, the WRAP feature changes to OFF. With the wrap-around feature off, the text is displayed just as it is transmitted by the other system and may extend beyond the right screen boundary. To turn WRAP back on again, press **CTRL 5** once more.

**IMPORTANT:** Whenever you change the WRAP feature, all data in your computer's available Random Access Memory (RAM) is erased. Be sure that the WRAP feature is in the desired mode (ON or OFF) *before* you start receiving data. Remember that the module begins with WRAP automatically on.

When saving or printing data, the WRAP should be on if you wish to output lines with 40 characters or less. It should be off if you wish to output lines with a maximum of 80 characters. With the wrap-around feature off, you can save or print greater amounts of material at one time since the Home Computer outputs one page at a time. The longer line is also desirable if you are receiving charts or tables.

If the WRAP is off and you are receiving data, the module displays the first portion of each incoming line of information. (The number of characters that are displayed depends on the column width you selected on the COMMUNICATION SETUP display.) The final position in the line shows the rest of the transmitted line one character at a time. To view the data which extends beyond the screen boundaries, use the arrow keys as explained in the section, "Reviewing Data with the Arrow Keys." Since many systems pause after sending 24 lines of data, you might wish to review the data at the end of each page.

### **CONTROL 6 (CASE)**

**CTRL 6 (CASE)** controls the case of the characters to be sent to the remote system. Unless you change the case setting, the module sends upper case letters. To change to lower case, hold down the **CTRL** key and press **6**. To send upper case again, hold down the **CTRL** key and press **6** again. *Note:* The remote computer controls the case of the characters you receive.

### **CONTROL 7 (PAGE)**

This feature allows you to scroll the text on your display up or down 24 lines at a time, or left or right one page at a time, as determined by the column width you selected. For details, see the section "Reviewing Data with the Arrow Keys."

### **CONTROL 0 (EXIT)**

Pressing **CTRL 0 (EXIT)** returns the computer to the master title screen, ending a session with the module. The EXIT sequence closes all open files, protecting any data stored on your disk system. All data not saved on a mass storage device is lost. Note that the EXIT key sequence does not "sign off" with the other system. For information on signing off, refer to "Ending Data Exchange."

**IMPORTANT:** Pressing **QUIT** also returns the computer to the master title screen, but it does *not* close all open files. If you exit the module by any means other than **CTRL 0**, such as pressing **QUIT** or turning the computer console off, the data you have saved on diskette may be lost.

### **FUNCTION V (DELETE)**

Pressing **FCTN V (DELETE)** transmits a DELETE control character (ASCII 127) to the other system. This is useful if you make a typing error while transmitting a code or other information to the other system. If the other system accepts the signal, it deletes either the most recent character you sent or the most recent line of text you sent. (To find out which is deleted, consult the other system's instruction manual.)

### **CONTROL . (ESCAPE)**

Pressing **CTRL . (ESCAPE)** sends an escape (ESC) signal to the other system. Since the results of pressing ESCAPE are not always the same, check the other computer system's owner's manual for the meaning of this function.

### CONTROL / (BREAK)

Holding down the **CTRL** key and pressing / (slash) sends a **BREAK** signal to the other system. This function "gets the attention" of the other system and signals it to stop transmitting data. Some of the meanings for **BREAK** are:

- All data transmission is terminated.
- All transmission is delayed until you send a message to the other system.
- The other system displays a selection list for you to select a new topic.

The results obtained by pressing **CTRL / (BREAK)** depend on the other computer system.

### RECALLING STORED DATA FROM A DISKETTE OR CASSETTE

*Note:* The Terminal Emulator II module does not provide a means to retrieve data stored on a diskette or cassette. To do so, you will need an Extended BASIC module (sold separately). The following is an Extended BASIC program which will retrieve data stored on a diskette or cassette and then write the data to the screen or a printer.

```
100 PRINT "ENTER 'device.filename'"
110 INPUT "----- ":FILE$
120 OPEN #1:FILE$, INPUT, DISPLAY, VARIABLE 80
130 INPUT "PRINTER (Y/N)? ":C$
140 IF C$="N" THEN 220
150 PRINT "ENTER 'printer name'"
160 INPUT "----- ":P$
170 OPEN #2:P$,OUTPUT, DISPLAY
180 LINPUT #1:A$
190 IF EOF(1) THEN 260
200 PRINT #2:A$
210 GOTO 180
220 LINPUT #1:A$
230 IF EOF(1) THEN 260
240 PRINT A$
250 GOTO 120
260 END
```

*Note:* When using a cassette, the **OPEN** in line 120 should have **FIXED 80** instead of **VARIABLE 80**. Also with a cassette, there is no **EOF** marker on the tape; the program ends with an **I/O** error when all the data has been read.



### FILE TRANSFER

The module's file transfer feature enables you to transfer a file from a mass storage device connected to your computer to a mass storage device connected to another computer system, without having to load the file into your computer's memory first. The other system can also transfer files to your computer. This enables you to exchange programs with your friends, as well as send and receive files of information from a data-base service. (*Note:* Check with the data-base service to find out whether the service makes provisions for transferring files.)

To perform a file transfer, the following conditions must be met:

- The TI Disk Memory System or a compatible cassette recorder must be properly connected to your computer and turned ON. If you're using a cassette recorder, it must be connected to the triple-plug end of the Cassette Interface Cable.
- The other system must follow the protocols of the Home Computer. (See "Transmission of Graphics and Sound" for information.)

If the file transfer is taking place between two disk systems, you may transfer a program or a data file. If the transfer is taking place between two cassette recorders, you can only transfer a fixed-length data file with records that have a maximum length of 192 bytes. A file stored on cassette *cannot* be transferred to a disk system. A diskette-to-cassette transfer can be performed, *provided* the diskette file is a fixed-length data file with records having a maximum length of 192 bytes. However, to transfer data from a diskette to a cassette, the fixed length of the data file should be 40 or more. Otherwise, the transfer occurs too slowly, and the sending system may end the transfer before it's complete.

### File Transfer to Another System

To transfer a file from your system to the other system, hold down the **CTRL** key and press **4** (TRANSFER). The module then displays the following:

PLEASE ENTER DEVICE NAME  
TO TRANSMIT DATA FROM

The device names which you may enter are DSK1, DSK2, and DSK3 (for TI Disk Drives 1, 2, and 3) or CS1 (for cassette recorder 1). Type the name of the device from which you are transferring the file and then press **ENTER**.

The displays that appear next depend on whether you're using a disk system or a cassette recorder.

#### File Transfer from Diskette

If you indicate that the transfer will take place from a TI Disk Memory Drive, the module asks you to enter the name of the file you wish to transfer to the other system. Make sure that the diskette with the desired file is inserted into the proper disk drive. Then type the file name and press **ENTER**. (Note that you do not need to include the disk drive number as part of the file name. For example, a file named TEST80 that's located in Disk Drive One is simply entered as TEST80.)

If the file that you are transferring is a program file, is in internal format, or has variable-length records, the file transfer starts automatically. If not, the module asks whether the file should be sent as 7-bit data or 8-bit data. If the file only contains data with standard ASCII upper and lower case letters and punctuation (no control characters), select option 1 for *7 Bit Data*. If the file includes ASCII control characters, select option 2 for *8 Bit Data*. The file transfer requires less time with the 7-bit option than it does with the 8-bit option. Once you select the data bits, the file transfer begins. *Note:* Files stored on diskette which have variable-length records or an internal format file are automatically sent as 8-bit data.

For a description of what takes place next, see "File Transfer in Progress."



### File Transfer from Cassette

If you indicate that the transfer will take place from a cassette recorder, the module asks you to enter the record size that you used when creating the data file. Type a number (up to 192) to indicate the record size, and press **ENTER**. Next, the module asks you to indicate whether the file is to be sent as 7-bit data or 8-bit data. (The difference between these two options is explained in "File Transfer from Diskette.") Select option 1 for *7 Bit Data* or 2 for *8 Bit Data*. The module then states that the file transfer is in progress. The following section describes what happens next.

### File Transfer in Progress

The information shown next depends on whether the Home Computer is the sending or receiving system. If it is the sending system, the Terminal Emulator II module displays

BLOCK	RECORD	RETRIES
000	00	0

and notifies the receiving system that the module is going to send a data file. The module then waits for a command from the other system indicating it is ready to receive the data.

If a remote system sends a file transfer to a Home Computer, a series of messages appears on the display of the Home Computer (the receiving system). First, the message

HOST HAS STARTED FILE TRANSFER

appears on the display. The Home Computer may then cancel the transfer by means of the **CTRL 3** (CANCEL) function. (Other systems may cancel the transfer by sending an appropriate escape sequence as specified by the Home Computer's protocols.)

After a short pause, the message

PLEASE ENTER DEVICE NAME  
TO OUTPUT DATA TO

appears on the receiving Home Computer's display. The acceptable device names are DSK1, DSK2, and DSK3 (for TI Disk Memory Drives 1, 2, and 3) or CS1 (for cassette recorder 1). Make sure that a diskette (or cassette) is inserted into the appropriate mass storage device. Then type the proper device name and press **ENTER**.

If the receiving computer is outputting data to a disk system, the display then states **PLEASE ENTER FILE NAME**. Type the desired file name and press **ENTER**. The module does not ask you for a file name if the data is being output to a cassette.

The file transfer now begins, and the following information appears on the display of both the sending and the receiving systems:

BLOCK	RECORD	RETRIES
001	01	00

**BLOCK** and **RECORD** state how much information is being transmitted. There are several records in each block of data. A block is one sector on a diskette. On a cassette, the size of a block varies, depending on the length of the records.

**RETRIES** indicates the number of times the sending system has to restart the transmission of a record. The transfer of a record is restarted whenever an error (such as a dropped bit) is detected in the transmission. If the sending system fails to make a successful transfer of any record after the eighth retry, the file transfer is automatically terminated by the receiving system.

If you are communicating with a data base via telephone and continually get a high number of retries, you may have a bad connection. You may be able to correct the problem by hanging up and starting over.

*Note:* For best results, do not press the paper advance button on the Thermal Printer during data transmission. Otherwise, you will lose some of the data sent from the other computer system.

Upon completion of a file transfer, the message **SUCCESSFUL FILE TRANSFER** appears on the displays of both systems.

### **TRANSMISSION OF GRAPHICS AND SOUND**

For information on transmitting files, graphics, and sound with the Terminal Emulator II module, write for the protocol manual at the following address:

Computer Manuals — Terminal Emulator Protocols  
Texas Instruments Incorporated  
P.O. Box 53  
Lubbock, Texas 79408



### **REVIEWING DATA WITH THE ARROW KEYS**

The data that you receive often takes up more than one page in your Home Computer's available memory. (A page is the amount of data on one display.) Also, the lines of data may extend beyond the screen boundaries. You can view this stored data in several ways by means of the **CTRL 7 (PAGE)** function and the arrow keys on your console keyboard.

To scroll text upward or downward a line at a time, press **FCTN**  $\uparrow$  or **FCTN**  $\downarrow$ . To scroll the text up or down one page at a time, hold down the **CTRL 7 (PAGE)** key and press **7 (PAGE)**. Then press **FCTN**  $\uparrow$  or **FCTN**  $\downarrow$ , as desired.

**FCTN**  $\leftarrow$  and **FCTN**  $\rightarrow$  move the text to the left or right a column (one character) at a time, for viewing data which extends beyond the screen boundary. To shift text to the left or right a page at a time (i.e., by the column width you selected), press **CTRL 7 (PAGE)** and then press **FCTN**  $\leftarrow$  or **FCTN**  $\rightarrow$ , as appropriate. Note that **CTRL 7 (PAGE)** only works with **FCTN**  $\leftarrow$  and  $\rightarrow$  when the **WRAP** feature is **OFF**.

If you press any arrow key which would shift or scroll the display beyond the boundary of the text, the computer gives a warning beep and the display does not change.

*Note:* Occasionally you may want to receive several pages of data and then sign off from data base before reviewing the data with the arrow keys. If you accidentally press a key other than **PAGE** or an arrow key as you review the data, your computer system may appear to "lock up." To correct the problem, switch your TI Telephone Coupler (Modem) from **FULL duplex ("F")** to **TEST ("TST")** and then back to **FULL duplex**. Then you can continue your review.



**Appendix A**

*Standard ASCII Control Characters*

The Terminal Emulator II module enables your Home Computer to send control characters 1 through 31 of the ASCII Character Set. ASCII control characters are recognized by many computer systems. However, since the meaning of control characters is determined by the remote computer, check the necessary manual to make sure the other system recognizes the standard ASCII meaning of the control characters you want to send.

The first two columns of this table give the decimal and hexadecimal values of the control characters. The mnemonic code column gives abbreviated meanings to aid you in remembering the characters. The fourth column states the key(s) you should press to send the control characters. (*Note:* Whenever CONTROL or SHIFT precedes a second key, hold down the CTRL or FCTN key while you press the second key. For example, to send an "end of transmission" signal, hold down the CTRL key and press D.) The comments column explains the standard meaning of each character as used by most computer systems.

ASCII Character Number	ASCII Hex Number	Mnemonic Code	Press	Comments
1	01	SOH	CTRL A	Start of heading
2	02	STX	CTRL B	Start of text
3	03	ETX	CTRL C	End of text
4	04	EOT	CTRL D	End of transmission
5	05	ENQ	CTRL E	Enquiry
6	06	ACK	CTRL F	Acknowledge
7	07	BEL	CTRL G	Bell
8	08	BS	CTRL H	Backspace
9	09	HT	CTRL I	Horizontal tabulation
10	0A	LF	CTRL J	Line feed
11	0B	VT	CTRL K	Vertical tabulation
12	0C	FF	CTRL L	Form feed
13	0D	CR	ENTER	Carriage return
14	0E	SO	CTRL N	Shift out
15	0F	SI	CTRL O	Shift in
16	10	DLE	CTRL P	Data link escape
17	11	DC1	CTRL Q	Device control 1 (X-ON)
18	12	DC2	CTRL R	Device control 2
19	13	DC3	CTRL S	Device control 3 (X-OFF)
20	14	DC4	CTRL T	Device control 4
21	15	NAK	CTRL U	Negative acknowledge
22	16	SYN	CTRL V	Synchronous idle
23	17	ETB	CTRL W	End of transmission block
24	18	CAN	CTRL X	Cancel
25	19	EM	CTRL Y	End of medium
26	1A	SUB	CTRL Z	Substitute
27	1B	ESC	CTRL .	Escape
28	1C	FS	CTRL ;	File separator
29	1D	GS	CTRL =	Group separator
30	1E	RS	CTRL 8	Record separator
31	1F	US	CTRL 9	Unit separator
127	7F	DEL	FCTN V	Delete



## Appendix B

### Setting Up a Log-on File

As discussed in "Preparing to Send/Receive Data," you can set up a program on diskette which allows you to log on to the other system automatically. The program should provide all the data, such as control characters and a user-identification number, which your computer must send to the other system to begin data exchange. The automatic log-on option is only available if your Home Computer system includes the TI Disk Memory System.

Before setting up your log-on file, sign on to the other computer system several times and note how long the other system delays before responding to each of your inputs. Then you can include the necessary pauses in your file. Note that, with a time-sharing system, the response time varies, depending on the number of people using the system.

To set up an appropriate log-on program, your file must have the following format:

```
FILE ORGANIZATION:  VARIABLE, 80 BYTES.
OUTPUT RECORD:      > HEX 31 FOLLOWED BY THE ACTUAL
                     ASCII DATA TO BE SENT.
INPUT RECORD:        > HEX 32 FOLLOWED BY ONE BYTE
                     GIVING THE DESIRED TIME DELAY IN
                     SIXTIETHS OF A SECOND.
```

The Terminal Emulator II module should send output records with the desired text and/or control characters to the RS232 Interface for transmission to the other system. Each output record consists of one or more characters or signals that you need to send the other system at once. For instance, you may need to send two carriage returns, a location code, and a user ID number. Therefore, your log-on program would include three output records.

The program in this appendix enables you to set up your own log-on file. When you run the program, it prompts you to enter each output record you want to send the other system, as well as each input record needed for a time delay. Once you complete the records and close the file, the program creates a separate log-on file on the diskette.

*Note:* Once you close the file, you cannot change the information you have entered in each record. However, you may run the program again and reenter the information.

When you run the program to set up a log-on file, the computer first asks, WHAT IS THE LOG-ON FILE NAME. Type LOGON (the default file name used by the module) or another file name, if desired, and press **ENTER**. The computer then asks WHAT TYPE OF RECORD and offers you the choice of pressing **1** for an output record, **2** for an input record, or **3** to close the file.

First, you need to set up an output record, so type **1** and press **ENTER**. The computer then asks you to ENTER TYPE SELECTION and offers you the choice of pressing **1** for text, **2** for control value, or **3** to end the record. If the information you need to send the other system is alphanumeric (standard numbers and letters on your keyboard), select option 1. To send a control character, select option 2. Note that a carriage return is sent as a control value, using the mnemonic code CR, as explained below.

If you select option 1 for *Text*, the prompt TEXT= appears on the display. Type all the letters and/or numbers of the information you wish to send in this output record, and press **ENTER**. (Don't forget to include any spacing required by the other system.)

On the other hand, if you select option 2 for *Control Value*, the prompt CNTRL CODE= appears. Type the mnemonic code of the first control character you wish to send, and press **ENTER**. To send a control C, for instance, type and enter ETX. You can also enter a single character, such as N for control N, instead of the mnemonic codes listed in *Appendix A*. *Note:* In the log-on file program, a control J is LF and a control M is CR, instead of the codes listed in *Appendix A*.

Once you finish the entry, the computer asks you to ENTER TYPE SELECTION again. If the information in the current record is alphanumeric, you have already entered all of the necessary information. However, if the record contains more than one control character, select option 2 and follow the same procedure to enter the next control character. Continue to add new information to the output record as necessary. When the output record includes all the necessary data, select option 3. *End of Record*.



Once you end the record, the computer returns to the display which asks WHAT TYPE OF RECORD. When the remote system is supposed to respond to an output record, include an input record after the output record so that the module waits for the response. To create an input record, enter 2 for *Input Record*. The program then asks you to enter the time delay (in tenths of a second) that you want the computer to wait before sending the next output record. (Note: Since the Terminal Emulator II module times the delay in sixtieths of a second, line 800 of the log-on program converts the time delay from tenths to sixtieths of a second.) The time delay you enter depends on your communications setup. Generally, you'll need a longer time delay if you are communicating with the other system by telephone instead of direct cable. Enter a whole number from 1 to 42 to indicate a delay from .1 second to 4.2 seconds. To delay longer than 4.2 seconds, include more than one input record.

The input record is completed once you enter the time delay, and the program returns to the display asking WHAT TYPE OF RECORD. Continue to create new output and input records as before. When you have created the last output record you need and the computer again asks WHAT TYPE OF RECORD, select option 3 for END OF FILE. Your log-on program is now completed.

The program to set up a log-on file is as follows:

```
100 PRINT "WHAT IS LOG-ON FILE NAME?"
110 INPUT R$
120 S$="DSK1."&R$
130 OPEN #2:"TP",OUTPUT
140 OPEN #1:S$
150 GOSUB 260
160 IF FLAG=1 THEN 190
170 PRINT #1:A$
180 GOTO 150
190 CLOSE #1
200 OPEN #1:S$
210 INPUT #1:A$
220 GOSUB 530
230 IF EOF(1) THEN 250
240 GOTO 210
250 END
260 PRINT "WHAT TYPE RECORD?"
```



```
270 PRINT "1 FOR OUTPUT"
280 PRINT "2 FOR INPUT"
290 PRINT "3 FOR END OF FILE"
300 INPUT B
310 IF B=1 THEN 360
320 IF B=2 THEN 760
330 IF B<>3 THEN 270
340 FLAG=1
350 RETURN
360 A$="1"
370 GOSUB 700
380 FLAG=0
390 IF B=2 THEN 450
400 IF B=3 THEN 350
410 IF B<>1 THEN 370
420 INPUT "TEXT = ":C$
430 A$=A$&C$
440 GOTO 370
450 INPUT "CNTRL CODE = ":D$
460 GOSUB 830
470 IF C$<>"ERROR" THEN 510
480 PRINT "UNKNOWN CONTROL CODE"
490 CALL SOUND(500,150,1,152,1,154,1)
500 GOTO 450
510 A$=A$&C$
520 GOTO 370
530 X=2
540 IF SEG$(A$,1,1)="1" THEN 610
550 PRINT #2:"INPUT DELAY TIME";
560 C$=SEG$(A$,2,1)
570 B=ASC(C$)
580 B=B/6
590 PRINT #2:B
600 RETURN
610 PRINT #2:"OUTPUT VALUES"
620 Z=LEN(A$)
630 IF X>Z THEN 690
640 C$=SEG$(A$,X,1)
650 B=ASC(C$)
660 PRINT #2:C$;B
670 X=X+1
```

```

680 GOTO 630
690 RETURN
700 PRINT "ENTER TYPE SELECTION"
710 PRINT "1 FOR TEXT"
720 PRINT "2 FOR CONTROL VALUE"
730 PRINT "3 FOR END OF RECORD"
740 INPUT B
750 RETURN
760 A$="2"
770 PRINT "HOW MANY .1 SECONDS DELAY?"
780 INPUT "AFTER RECEPTION (42 MAX)?:":B
790 IF B>42 THEN 770
800 B=B*6
810 A$=A$&CHR$(B)
820 RETURN
830 IF LEN(D$)=1 THEN 930
840 RESTORE
850 FOR I=0 TO 31
860 READ E$
870 IF D$<>E$ THEN 900
880 C$=CHR$(I)
890 RETURN
900 NEXT I
910 C$="ERROR"
920 RETURN
930 B=ASC(D$)
940 IF B<64 THEN 960
950 IF B<96 THEN 980
960 C$="ERROR"
970 RETURN
980 B=B-64
990 C$=CHR$(B)
1000 RETURN
1010 DATA NUL,SOH,STX,ETX,EOT,ENQ,ACK,BEL
1020 DATA BS,HT,LF,VT,FF,CR,SO,SI
1030 DATA DLE,DC1,DC2,DC3,DC4,NAK,SYN,ETB
1040 DATA CAN,EM,SUB,ESC,FS,GS,RS,US

```

Note: To use a printer other than the TI Thermal Printer, change "TP" in line 130 to the appropriate device name. If you are not using a printer, omit lines 130, 200 to 240, and 530 to 690.



### Appendix C

#### Accessing Text-to-Speech in TI BASIC

With the text-to-speech system included in the Terminal Emulator II module, the computer can speak either entire English words or strings of allophone data, as shown here.

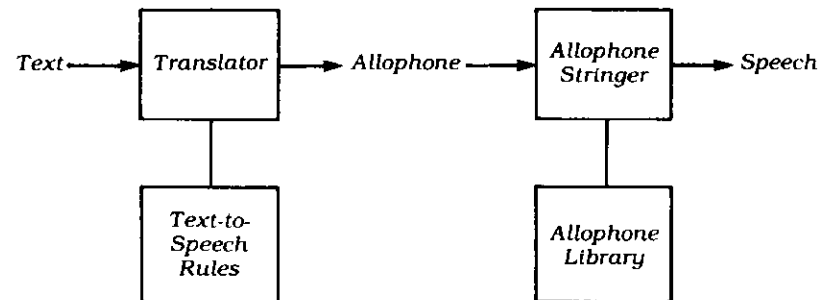

When you input text to be spoken, the module first translates the English text into its allophonic equivalent, using the speech rules programmed into the module. The rules also include symbols for sentence contouring. Next, the allophone strings, which may include pitch modifiers, are converted to Linear Predictive Coding (LPC) strings. The LPC strings are then processed through the Speech Synthesizer and spoken.

The text-to-speech system requires the use of the Speech Synthesizer unit and the Terminal Emulator II module. To make sure the system is set up properly, select TI BASIC, type

```
OPEN #1:"SPEECH",OUTPUT
```

and press **ENTER**. If no error message appears, you are ready to continue. If you receive an error message, make sure that the speech unit and module are both properly attached to the computer, and try again.

### Speaking Text

To include spoken text in a TI BASIC program, an OPEN statement for the speech synthesizer is required. The statement is in the form

```
OPEN #file-number:file-name[,file-attributes]
```

where the file attributes are DISPLAY, OUTPUT, SEQUENTIAL, and VARIABLE. Since some of the attributes are default values, the following OPEN statements are equivalent:

```
10 OPEN #1:"SPEECH",OUTPUT  
10 OPEN #1:"SPEECH",OUTPUT,DISPLAY,SEQUENTIAL,  
VARIABLE xx
```

In the VARIABLE attribute, you can specify any value from 1 through 255. However, the value you enter determines the number of characters that the speech unit will accept.

Now let's try an example. Type

```
OPEN #1:"SPEECH",OUTPUT  
PRINT #1:"HELLO THERE"
```

and press **ENTER**. Remember, the system can speak any English words. Try some examples of your own, and then try one including a numeric evaluation. For instance, enter the following.

```
PRINT #1:4*ATN(1)
```

The computer should speak the value of "pi." Notice that the decimal point is pronounced "point." Other special symbols which are pronounced are explained later in this section.

As you listen to the computer speak, you may decide to include pitch and slope in the output. Pitch determines the highness of the spoken sounds, while slope is the rate at which the pitch changes in the spoken phrase. To set the pitch and slope, include the following in a special output record:

```
//xx yyy
```

where xx is the pitch period and yyy is the slope level indication. Be sure to include a space between xx and yyy. The pitch period should be a value from 0 through 63, with 0 sounding like a whisper, 1 being the highest pitched voice, and 63 being the lowest pitched voice. The slope level should be a value from 0 through 255, with the best results occurring when the slope is 32 times 10% of the pitch. Thus, for a pitch of 43, the slope would be  $32 \times 4 = 128$ . *Note:* The default values for pitch and slope are 43 and 128, respectively.



Note that the slope indicator you select must meet the following limits:

$$yyy < [xx - 1] * 16$$

or

$$yyy < [63 - xx] * 16$$

Otherwise, the speech may be garbled. For example, with a pitch of 1 and a slope of 128, the phrase "This is a test" becomes garbled.

In addition to pitch and slope, the speech unit recognizes five types of special characters: alphabetical characters, numerical characters, pause and break characters, inflection symbols, and special symbols.

*Alphabetical Characters* — If the text includes an alphabetic character that is not preceded or followed by an alphabetic character, the letter is pronounced as a single character. For example,

```
PRINT #1:"A B C"
```

is pronounced "ay bee sea."

*Numerical Characters* — The numbers 0 through 9 and the symbols ":", "(", ")", " " (space), and "-" are numerical characters. The numbers are always pronounced as such, but the special symbols are only pronounced if they *directly precede* a numerical character. Otherwise, they are ignored or treated as a symbol from another group, if appropriate.

*Pause and Break Characters* — The pause and break characters are ":", "(", ")", "!", "?", ":", and ";". Notice that both the period and comma must be followed by a space. The length of the pause caused by the character is either .1 second (short pause) for the comma or .45 second (long pause) for the others. In addition to generating pauses, the characters affect the inflection contour of the phrase if a primary stress point (see "Inflection Symbols") has been indicated. The period and question mark both specify a rising contour; all other codes specify a falling contour. For more information, see the following paragraph.

*Inflection Symbols* — The symbols “^”, “\_”, and “>” are the inflection symbols. The first two, “^” and “\_”, actually change the inflection in a word, while the last one, “>”, shifts stress points within a word. Since each non-alphabetic character automatically causes a word break, the inflection symbol for a word must precede the word. The “>” symbol can be used to stress the desired vowel within the word. Try the following examples and listen to the effects created with the inflection symbols.

```
PRINT #1:" ^ SUPERB"  
PRINT #1:" ^ > SUPERB"  
PRINT #1:" _WHAT ^ TIME IS _IT"
```

As you listen to these examples, notice that the “^” indicates a *primary* stress point, of which you can include only one per line. The symbol “\_” indicates a secondary stress point, of which the number per line is basically unlimited. If more primary stress points than one are included in a phrase (words are not separated by break characters), the first one is given primary stress, and all others become secondary.

*Special Symbols* — The following table lists the special symbols and gives the pronunciation of each.

Symbol	Pronunciation
@	at
\$	dollar
%	percent
&	and
*	asterisk
(	open
)	close
=	equals
/	slash

**IMPORTANT:** Since the text-to-speech system is based on a set of rules for pronouncing English words, you may find it necessary to misspell an occasional word so that the pronunciation is correct.



Here is a TI BASIC program that lets you access the module's speech capabilities:

```
100 OPEN #1:"SPEECH",OUTPUT  
110 INPUT "PHRASE->":A$  
120 PRINT #1:A$  
130 GOTO 110
```

When you run the program, the computer asks you to input a phrase. Type any words, letters, or numbers you wish to hear, and then press **ENTER** to hear the computer speak your input. The computer then prompts you to enter additional phrases. To change the pitch and slope of the speech, type

//xx yyy

(where xx is the pitch and yyy is the slope) and press **ENTER** when the computer asks you to input a phrase. Then the next time you are asked to enter a phrase, type the information you want to hear. The computer will speak the phrase, incorporating the new pitch and slope.

#### *Allophone Speech*

If you want to experiment with creating new sounds or special words, you can use the allophone speech programmed into the Terminal Emulator II module. To use allophones, you must first access that part of the program through an OPEN statement. The format is

```
OPEN #file-number:file-name[.file-attributes]
```

where the attributes are INTERNAL, SEQUENTIAL, and VARIABLE. Unless otherwise specified, the program uses 255-byte records. Since some of the attributes are default values, the following statements are equivalent.

```
OPEN #1:"ALPHON",INTERNAL
```

```
OPEN #1:"ALPHON",INTERNAL,SEQUENTIAL,VARIABLE
```

Any of the modes (UPDATE, OUTPUT, INPUT, and APPEND) can be specified, with APPEND functioning like OUTPUT. Notice that the file-type with allophone speech must be INTERNAL, rather than DISPLAY.

For the system to speak an allophone string, you would use the PRINT command. Note, however, that this command expects only one string of allophone codes. Therefore, in the command

```
PRINT #1:CHRS(22);CHRS(56)
```

the program would only recognize allophone 22. To include more than one allophone string in a PRINT command, include the "&" symbol to concatenate the strings. Thus, the previous example would be written as

```
PRINT #1:CHRS(22)&CHRS(56)
```

to speak both strings.

To access the allophones included in a phrase, include the INPUT command in your TI BASIC program. This command causes the computer to speak the allophone string of the most recent phrase spoken with the Speech Synthesizer. For example, try this program.

```
100 OPEN #1:"SPEECH",OUTPUT
110 OPEN #2:"ALPHON",INTERNAL
120 PRINT #1:"I AM THE T I HOME COMPUTER"
130 PRINT #1:"HELLO"
140 INPUT #2:A$
150 PRINT #2:A$
```

Line 140 assigns the allophone string for "HELLO" to A\$, and line 150 tells the computer to speak that phrase again.

The codes for allophone strings are listed at the end of this appendix. In addition to these, the codes 249 through 255 have special functions as explained here.

Code 249 indicates a secondary stress point when it's included in an allophone string. Code 250 functions as a sentence break code and must be followed in the string by two parameters: the first one gives the number of secondary stress points *before* the primary stress point, and the second one gives the number of secondary stresses *after* the primary stress. If the first parameter has a value of 254 (a gradually rising pitch) or 255 (a gradually falling pitch), the second parameter must specify the total number of vowels in the phrase.

Code 251 indicates that a new default slope parameter follows; the next byte (CHRS data) in the string gives the new slope parameter. To change the default pitch parameter, use code 252 followed by the new pitch parameter. Codes 253 and 254 signal a primary stress point with a rising or falling pitch contour, respectively. Code 255, which must be



followed by a byte which gives the pitch parameter for the allophone, functions as a temporary pitch-level modification for the allophone immediately following it.

Experiment with these codes to see their effect on the allophones. The following program illustrates the use of special function code 252.

```
100 OPEN #1:"ALPHON",INTERNAL
110 A$=CHRS(53)&CHRS(49)&CHRS(252)
120 A$=CHRS(252)&CHRS(30)&A$&CHRS(33)&A$
130 A$=A$&CHRS(36)&CHRS(67)
140 PRINT #1:A$
```

As you use allophone strings, keep the following restrictions in mind.

- The codes 128 through 248 are not allowed. Their use causes the computer to stop speaking.
- If you specify a pitch code larger than 63, it is masked off to 6 bits. Thus, for example, code 64 becomes code 0, and 96 becomes 32.
- You can enter any slope parameter. However, if the slope would create problems with the pitch, the slope is automatically adjusted.
- If more than one primary stress point per phrase is given, or if the number of secondary stress points indicated in the "start phrase" code (250) is incorrect, the pitch may cross 0 or 63, resulting in squeaking noises.

To create words from allophones, enter and run this TI BASIC program:

```
100 OPEN #1:"ALPHON",INTERNAL
110 INPUT "NUMBER OF SYLLABLES = ":A
120 B$=CHRS(250)&CHRS(255)&CHRS(A)
130 INPUT "NUMBER (LAST = 1000)-> ":C
140 IF C=1000 THEN 170
150 B$=B$&CHRS(C)
160 GOTO 130
170 PRINT #1:B$
180 GOTO 110
```

When you run this program, the computer asks you to enter the number of syllables in the word or phrase you're "building." It then asks you to enter the number of each allophone that you wish to include in the word(s). These numbers are listed at the end of this appendix. Be sure to enter the allophone numbers in the order that you want the allophones spoken. When you have finished your word(s), enter 1000 in response to the prompt for the allophone number. The computer then speaks the word(s) with the allophones you specified.

To break words into their constituent allophones, type and run this program:

```

100 OPEN #1:"SPEECH",OUTPUT
110 OPEN #2:"ALPHON",INTERNAL
120 INPUT "PHRASE ":A$
130 IF A$="" THEN 120
140 PRINT #1:A$
150 INPUT #2:B$
160 Z=LEN(B$)
170 FOR R=4 TO Z
180 PRINT ASC(SEG$(B$, R, 1))
190 NEXT R
200 GOTO 120

```

When you run the program, it prompts you to enter the phrase you want to break down into allophones. Once you enter a phrase, the computer speaks the phrase and lists the allophone number for each of the constituent allophones.

#### LIST OF ALLOPHONES

The following allophone list gives the number of each allophone in the Terminal Emulator II module and a sample word. Notice that in each word some of the letters are printed in boldface type. These boldface letters indicate the part of the word which represents the allophone sound for that number on the list. Although some of the words may seem to contain the same sound, there are variations in the allophones. These variations depend on two conditions: the location of the sound within a word, or the letters which precede or follow the sound. An example of the first condition is the "d" sound in "dig" and in "bed." Exemplifying the second condition is the "ar" sound in "card," which is longer than the "ar" sound in "cart" because the "ar" in "card" is followed by a voiced consonant, the "d."

As you use this list to construct words and sounds from allophones, you might want to check your pronunciations with a dictionary, such as *A Pronouncing Dictionary of American English* (John S. Kenyon and Thomas A. Knott, 1953).



Allophone Number	Sound	Allophone Number	Sound
1	addition	44	shoot
2	annuity	45	hut
3	delta	46	boot
4	on time	47	had
5	autonomy	48	odd
6	anonimlty	49	hide
7	eliminate	50	card
8	enough	51	loud
9	context	52	saw
10	ancient	53	seed
11	western	54	heel
12	synthesis	55	hear
13	inane	56	said
14	took on	57	there
15	donation	58	day
16	annual	59	heard
17	unique	60	hid
18	above	61	hill
19	instrument	62	think
20	underneath	63	boy
21	roses	64	could
22	basement	65	poor
23	seeker	66	core
24	ratio	67	low
25	funny	68	shoe
26	hat	69	mud
27	hot	70	skull
28	height	71	pull
29	cart	72	moon
30	house	73	like
31	sought	74	bowl
32	heat	75	awful, well
33	perce	76	may
34	set	77	hum
35	therapy	78	nice
36	take	79	sane
37	hurt	80	think
38	issue	81	thing
39	choice	82	real
40	cook	83	witch
41	poorly	84	which
42	horse	85	you
43	boat	86	bad



Allophone Number	Sound	Allophone Number	Sound
87	dab	107	cough
88	dig	108	space
89	bid	109	pie
90	give	110	nap
91	go	111	stake
92	bag	112	tie
93	jug	113	late
94	budge	114	church
95	this	115	fat
96	clothe	116	laugh
97	vine	117	hit
98	alive	118	home
99	zoo	119	hut
100	does	120	seem
101	azure	121	miss
102	beige	122	shine
103	skate	123	wash
104	case	124	thing
105	make	125	with
106	key		

Allophone #126 provides a short pause, and allophone #127 provides a longer pause.

#### CARING FOR THE MODULE

Command modules are durable solid-state devices, but they should be handled with the same care you would give any other electronic equipment. Keep the module clean and dry, and don't touch the recessed contacts.

#### CAUTION:

The contents of a module can be damaged by static electricity discharges.

Static electricity build-ups are more likely to occur when the natural humidity of the air is low (during winter or in areas with dry climates). To avoid damaging the module, just touch any metal object (a doorknob, a desk lamp, etc.) before handling the module.

If static electricity is a problem where you live, you may want to buy a special carpet treatment that reduces static build-up. These commercial preparations are usually available from local hardware and office supply stores.

#### IN CASE OF DIFFICULTY

If the module activities do not appear to be operating properly, return to the master title screen by pressing **QUIT**. Withdraw the module, align it with the module opening, and reinsert it carefully. Then press any key to make the master selection list appear. The title of the module should show up on this list. Press the appropriate key to select Terminal Emulator II. (Note: In some instances, it may be necessary to turn the computer off, wait several seconds, and then turn it on again.)

If the module is accidentally removed from the slot while the module contents are being used, the computer may behave erratically. To restore the computer to normal operation, turn the computer console off, and wait a few seconds. Then reinsert the module, and turn the computer on again.

If you accidentally leave the Terminal Emulator II module program, you may still be connected to the data-base service. To continue exchanging data, simply reselect the module and your communication parameters as you did before. If you are still signed on to the data base, you do not need to repeat the sign-on procedure. Thus, if you are using an automatic log-on file, do not reload the file. Note that any data stored in memory is lost when you leave the program.

If you have any difficulty with your computer or the TERMINAL EMULATOR II module, please contact the dealer from whom you purchased the unit and/or module for service directions.

Additional information concerning use and service can be found in your *User's Reference Guide*.

---

## TEXAS INSTRUMENTS HOME COMPUTER

---

### **THREE-MONTH LIMITED WARRANTY HOME COMPUTER SOFTWARE MODULE**

Texas Instruments Incorporated extends this consumer warranty only to the original consumer purchaser.

### **WARRANTY COVERAGE**

This warranty covers the electronic and case components of the software module. These components include all semiconductor chips and devices, plastics, boards, wiring and all other hardware contained in this module ("the Hardware"). This limited warranty does not extend to the programs contained in the software module and in the accompanying book materials ("the Programs").

The Hardware is warranted against malfunction due to defective materials or construction. **THIS WARRANTY IS VOID IF THE HARDWARE HAS BEEN DAMAGED BY ACCIDENT, UNREASONABLE USE, NEGLIGENCE, IMPROPER SERVICE OR OTHER CAUSES NOT ARISING OUT OF DEFECTS IN MATERIALS OR WORKMANSHIP.**

### **WARRANTY DURATION**

The Hardware is warranted for a period of three months from the date of the original purchase by the consumer.

### **WARRANTY DISCLAIMERS**

**ANY IMPLIED WARRANTIES ARISING OUT OF THIS SALE, INCLUDING BUT NOT LIMITED TO THE IMPLIED WARRANTIES OF MERCHANTABILITY AND FITNESS FOR A PARTICULAR PURPOSE, ARE LIMITED IN DURATION TO THE ABOVE THREE-MONTH PERIOD. TEXAS INSTRUMENTS SHALL NOT BE LIABLE FOR LOSS OF USE OF THE HARDWARE OR OTHER INCIDENTAL OR CONSEQUENTIAL COSTS, EXPENSES, OR DAMAGES INCURRED BY THE CONSUMER OR ANY OTHER USER.**

Some states do not allow the exclusion or limitation of implied warranties or consequential damages, so the above limitations or exclusions may not apply to you in those states.

### **LEGAL REMEDIES**

This warranty gives you specific legal rights, and you may also have other rights that vary from state to state.

### **PERFORMANCE BY TI UNDER WARRANTY**

During the above three-month warranty period, defective Hardware will be replaced when it is returned postage prepaid to a Texas Instruments Service Facility listed below. The replacement Hardware will be warranted for three months from date of replacement. Other than the postage requirement, no charge will be made for replacement.



TI strongly recommends that you insure the Hardware for value prior to mailing.

### **TEXAS INSTRUMENTS CONSUMER SERVICE FACILITIES**

Texas Instruments Service Facility  
P.O. Box 2500  
Lubbock, Texas 79408

Geophysical Services Incorporated  
41 Shelley Road  
Richmond Hill, Ontario, Canada L4C5G4

Consumers in California and Oregon may contact the following Texas Instruments offices for additional assistance or information.

Texas Instruments Consumer Service  
831 South Douglas Street  
El Segundo, California 90245  
(213)973-1803

Texas Instruments Consumer Service  
6700 Southwest 105th  
Kristin Square, Suite 110  
Beaverton, Oregon 97005  
(503)643-6758

### **IMPORTANT NOTICE OF DISCLAIMER REGARDING THE PROGRAMS**

The following should be read and understood *before* purchasing and/or using the software module.

TI does not warrant that the Programs will be free from error or will meet the specific requirements of the consumer. The consumer assumes complete responsibility for any decision made or actions taken based on information obtained using the Programs. Any statements made concerning the utility of the Programs are not to be construed as express or implied warranties.

**TEXAS INSTRUMENTS MAKES NO WARRANTY, EITHER EXPRESS OR IMPLIED, INCLUDING BUT NOT LIMITED TO ANY IMPLIED WARRANTIES OF MERCHANTABILITY AND FITNESS FOR A PARTICULAR PURPOSE, REGARDING THE PROGRAMS AND MAKES ALL PROGRAMS AVAILABLE SOLELY ON AN "AS IS" BASIS.**

**IN NO EVENT SHALL TEXAS INSTRUMENTS BE LIABLE TO ANYONE FOR SPECIAL, COLLATERAL, INCIDENTAL, OR CONSEQUENTIAL DAMAGES IN CONNECTION WITH OR ARISING OUT OF THE PURCHASE OR USE OF THE PROGRAMS AND THE SOLE AND EXCLUSIVE LIABILITY OF TEXAS INSTRUMENTS, REGARDLESS OF THE FORM OF ACTION, SHALL NOT EXCEED THE PURCHASE PRICE OF THE SOFTWARE MODULE. MOREOVER, TEXAS INSTRUMENTS SHALL NOT BE LIABLE FOR ANY CLAIM OF ANY KIND WHATSOEVER BY ANY OTHER PARTY AGAINST THE USER OF THE PROGRAMS.**

Some states do not allow the exclusion or limitation of implied warranties or consequential damages, so the above limitations or exclusions may not apply to you in those states.



The world of telecommunications offers something for everyone...stock market quotes, tax advice, computer games, program swapping. The Terminal Emulator II Command Module lets you link your Home Computer to this world with new dimensions in graphics and sound, including text-to-speech capabilities! *Note:* Although the module can exchange textual data with a subscription data-base service, not all data-base services are capable of utilizing the module's graphics, sound, speech, and file transfer features. Before attempting to access these features, check with the data-base service.

**Terminal Emulator II** module features provide:

- Text and Graphics Modes — You can receive text or color graphics.
- Text-to-Speech Capability — You can instruct the computer to read *any* displayed text aloud. This feature can also be accessed in TI BASIC! (*Note:* The Texas Instruments *Solid State Speech*™ Synthesizer (Model PHP 1500)\* must be connected to the computer to utilize the speech capability.)
- And much more — A wide variety of functions makes it easy for you to work with your data.

*Note:* To activate the Terminal Emulator II module, a TI RS232 Interface (Model PHP1700)\* must be attached to the computer. If you are contacting a remote computer via telephone, a TI Telephone Coupler (Modem)\* is required in addition to the TI RS232 Interface. The RS232 Interface is not required for utilizing text-to-speech in TI BASIC.

**Adds 28K bytes of active memory with stored program to your TI Home Computer.**

\*sold separately

Command Module program and data base contents copyright © 1981 Texas Instruments Incorporated.



TEXAS INSTRUMENTS  
INCORPORATED  
DALLAS, TEXAS

---

## ADDENDUM

### *Terminal Emulator II Owner's Manual*

---

If you own a TI-99/4 Home Computer console, the following information will help you identify the special keys used in the Terminal Emulator II *Solid State Software*™ Command Module. A keyboard overlay also is included with the module to better assist you. The overlay includes a "dummy" key for your little finger on your right hand as an aid in touch typing.

With the Terminal Emulator II module, the SPACE key or SPACE BAR is used to send control characters. The SPACE key is labeled "CNTL" on your keyboard overlay. Throughout the manual, this key is referred to as the "CONTROL" key in discussions on accessing control functions.

Your overlay is comprised of white and orange key abbreviations. To select one of the functions printed in orange, hold down the SHIFT key and press the appropriate key function. To access the keys in white, hold down the SPACE key, labeled CNTL, and press the appropriate function. You also can hold down the SPACE BAR, instead of the SPACE key, and press the desired key function.

*Note:* The SPACE key or the SPACE BAR can be used to type a space without pressing any other key. The space character is sent when you release the key.

The Terminal Emulator II module enables your Home Computer to send control characters 1 through 31 and 127 of the ASCII Character Set. The first two columns of the following table give the decimal and hexadecimal values of the control characters. The mnemonic code column gives abbreviated meanings to aid you in remembering the characters. The fourth column states the key(s) you should press to send the control characters. (*Note:* Whenever CONTROL or SHIFT precedes a second key, hold down the CONTROL or SHIFT key while you press the second key. For example, to send an "end of transmission" signal, hold down the CONTROL key and press D.) The comments column explains the standard meaning of each character as used by most computer systems.

ASCII CHAR NUMBER	ASCII HEX NUMBER	MNEMONIC CODE	PRESS	COMMENTS
1	01	SOH	CNTL A	Start of heading
2	02	STX	CNTL B	Start of text
3	03	ETX	CNTL C	End of text
4	04	EOT	CNTL D	End of transmission
5	05	ENQ	CNTL E	Enquiry
6	06	ACK	CNTL F	Acknowledge
7	07	BEL	CNTL G	Bell
8	08	BS	CNTL H	Backspace
9	09	HT	CNTL I	Horizontal tabulation
10	0A	LF	SHIFT ENTER	Line feed
11	0B	VT	CNTL K	Vertical tabulation
12	0C	FF	CNTL L	Form feed
13	0D	CR	ENTER	Carriage return
14	0E	SO	CNTL N	Shift out
15	0F	SI	CNTL O	Shift in
16	10	DLE	CNTL P	Data link escape
17	11	DC1	CNTL Q	Device Control 1 (X-ON)
18	12	DC2	CNTL R	Device Control 2
19	13	DC3	CNTL S	Device Control 3 (X-OFF)
20	14	DC4	CNTL T	Device Control 4
21	15	NAK	CNTL U	Negative ac- knowledgement
22	16	SYN	CNTL V	Synchronous idle
23	17	ETB	CNTL W	End of trans- mission block
24	18	CAN	CNTL X	Cancel
25	19	EM	CNTL Y	End of medium
26	1A	SUB	CNTL Z	Substitute
27	1B	ESC	CNTL .	Escape
28	1C	FS	CNTL M	File separator
29	1D	GS	CNTL J	Group separator
30	1E	RS	CNTL 8	Record separator
31	1F	US	CNTL 9	Unit separator
127	7F	DEL	SHIFT V	Delete character